



SU FUTURO EN TECNOLOGIA

Circuitos Integrados * Semiconductores * Repuestos Industriales * Servicio Técnico * Instrumentación
Representantes exclusivos para el Ecuador de **KEPCO INC.** fabricantes de Fuentes de Poder

Baquerizo Moreno y Loja * Guayaquil – Ecuador

Tel: (4) 230-7996

Fax: (4) 230-7987

E-mail: erazoc@chipscom.com

Estimado cliente:

En las siguientes páginas encontrará la información solicitada por usted, confiamos son de utilidad.

Si necesita más detalles, por favor comuníquese conmigo hoy mismo.

Carlos Erazo
Gerente General

Chip's Cia. Ltda. Baquerizo Moreno y Loja * Guayaquil - Ecuador

Derechos Reservados

www.chipscom.com

INSTRUCTION MANUAL

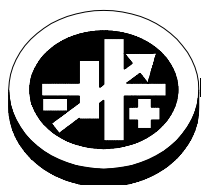

KEPCO An ISO 9001 Company.

FAW

KEPCO SINGLE OUTPUT 25 WATT HIGH FREQUENCY SWITCHING POWER SUPPLIES

I — INTRODUCTION

The Kepco FAW 25 Watt Series low profile high frequency switching power supplies employ flyback conversion and operate with a 70% efficiency with either a-c or d-c input. A thermistor soft-start circuit limits start-up surge. Surface mount technology permits efficient component layout for minimum mounting space. Four models may be selected for outputs of 5, 12, 15 or 24V. "POWER OK" logic and a green "POWER OK" light are provided. A steel cover (Model CA 25) is available as an option. Output voltage may be adjusted with a trimmer accessible near the input-output terminal strip. When the input is cut off, the output is maintained for 15 milliseconds minimum. EMI filtering meets FCC Class B rating and VDE 0871 Class B rating. This page contains specifications for each model of the FAW 25 Watt Series. Environmental specifications for each model are the same.

II — SPECIFICATIONS

The following specifications apply to FAW 25 Watt Series models. Other models are also available; consult your Kepco representative for their specifications.

TABLE 1. OUTPUT RATINGS AND SPECIFICATIONS, FAW 25W SERIES

MODEL	FAW 5-5K	FAW 12-2.1K	FAW 15-1.7K	FAW 24-1.1K	
OUTPUT VOLTS, d-c (NOMINAL)	5V	12V	15V	24V	
ADJUSTMENT RANGE	4.2-5.5V	10.8-13.2V	13.5-16.5V	21.6-26.4V	
OUTPUT CURRENT (NOMINAL)	5.0A	2.1A	1.7A	1.1A	
OUTPUT POWER (MAXIMUM)	25.0W	25.2W	25.5W	26.4W	
RIPPLE AND NOISE (mV p-p) 0-50°C 10-100% LOAD	source (typ)	9	17	17	
	source (max)	18	35	35	
	switching (typ)	31	32	42	57
	switching (max)	62	65	85	115
	spike noise (d-c—50MHz)	120	190	220	310
OVERVOLTAGE SETTING 25°C, NOM. INPUT	6.0-6.9V	13.7-15.7V	17.0-19.0V	27.0-30.5V	
OVERCURRENT SETTING 25°C, NOM. INPUT	5.5-7.5A	2.3-3.3A	1.9-2.8A	1.2-1.8A	

INPUT:

Voltage: 120V a-c/240V a-c nominal; Range 85-264V a-c; 110-370V d-c.

Frequency: Nominal 50-60 Hz; Range 47-440Hz (at 440Hz leakage current exceeds UL/VDE safety spec. limit).

Current (nominal output at rated load): @120V a-c rms: 0.55A typ., 0.7A max.; @240V a-c rms: 0.35A typ., 0.45A max.

Initial Turn-on Surge: (one-half of first input cycle): @120V a-c rms, 43A max., @240V a-c rms, 85A max.

STABILIZATION:

Source Effect: Range 85-132V a-c or 170-264V a-c, 1.0% typ.; 2.0% max.

Load Effect: Range 10%-100% load, 1.0% typ.; 2.0% max.

Temperature Effect: Range 0° to 50°C, 1.0% typ.; 2.0% max.

Combined Effect: 2.6% typ.; 4.0% max. (includes source, load, and temperature effects).

Drift: 0.1% typ.; 0.5% max. (1/2 hr-8 hr at 25°C).

RECOVERY CHARACTERISTICS: A step load change from 50% to 100% produces less than $\pm 4\%$ output excursion. Recovery occurs to within $\pm 1\%$ of the original setting in $< 2\text{ms}$ (t_r or t_f equal to or greater than $50\mu\text{sec}$ at load change).

START-UP TIME: 500 ms. maximum.

HOLDUP TIME: 15 ms. min (100V a-c), 20 ms. typ. (120V a-c).

DIELECTRIC STRENGTH:

Between input and output: 2KV a-c for one minute.

Between input and output with Y-capacitor removed: 3.75KV a-c for one minute.

Between input and case (ground): 2KV a-c for one minute.

INSULATION RESISTANCE: Between input and ground, output and ground, input and output; 100 Megohms min. (500V d-c).

KEPCO, INC. ● 131-38 SANFORD AVENUE ● FLUSHING, NY. 11352 U.S.A. ● TEL (718) 461-7000 ● FAX (718) 767-1102

<http://www.kepcopower.com> ● email: hq@kepcopower.com

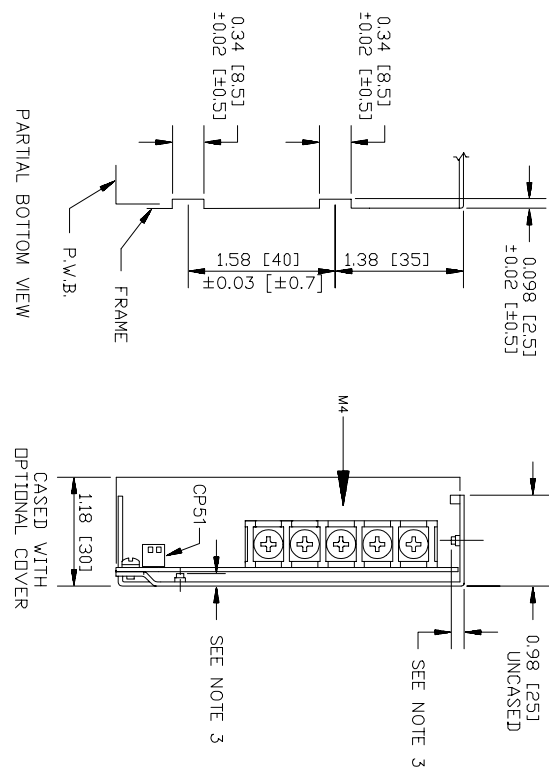
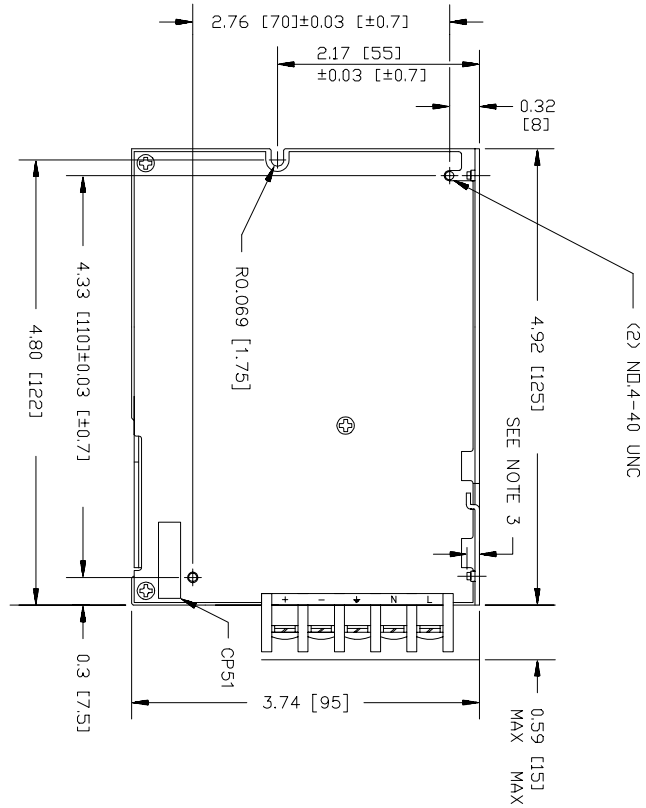
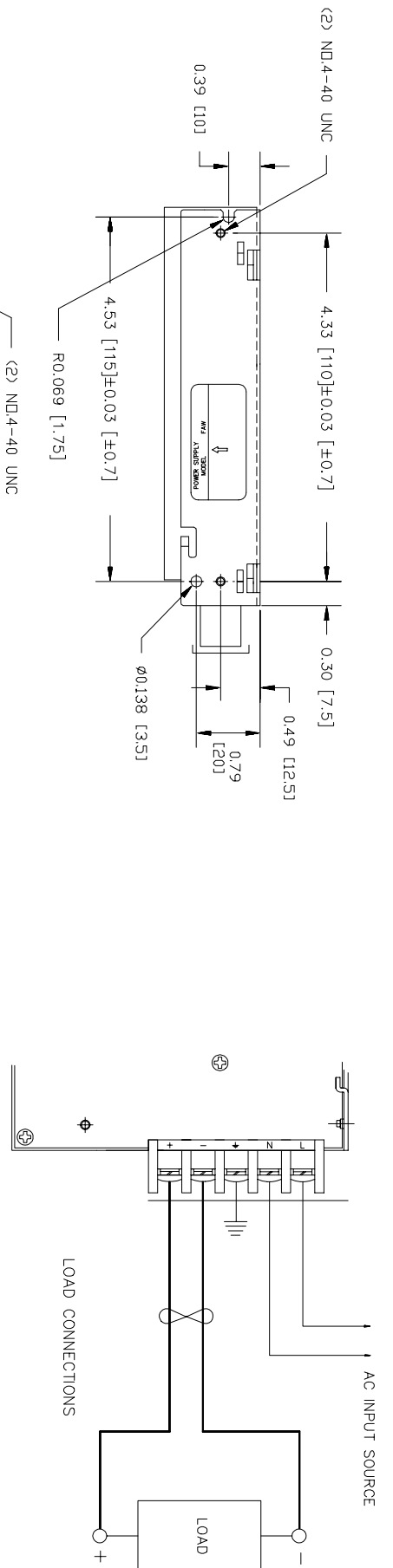

- NOTES:
1. DIMENSIONS IN PARENTHESSES ARE IN MILLIMETERS, OTHERS IN INCHES.
 2. TOLERANCES: ±.04 (±1) EXCEPT AS NOTED.
 3. MAXIMUM MOUNTING SCREW PENETRATION: 0.2 (5).

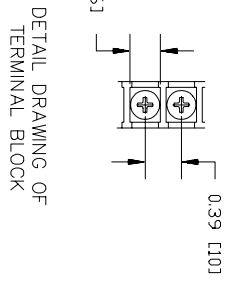

FIGURE 3. MECHANICAL OUTLINE DRAWING